

technical  
data sheet

**QB 110**

w 11,81x h 53,15x d 11,81"  
w 300x h 1350 x d 300mm

**instructions**

**use**

the base must be mounted with a stainless steel FHC screw and a 6-sided M6 wood insert.

the fixing of the document holder is secured by an FHC M4 screw and opening with an Allen key 1,3

**marking**

on the paper document (170gr max. not supplied) printing with a laser or inkjet printer.

**fastening**

free-standing

the design allows three connections with Qborne products through a link in black sandow rubber QB 120 (not included)

**cleaning**

alcoholfree household cleaning product with a soft piece of textile.

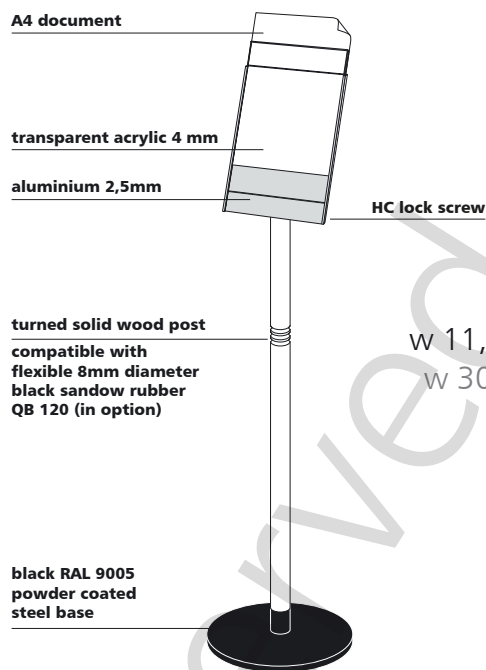

**sizes**

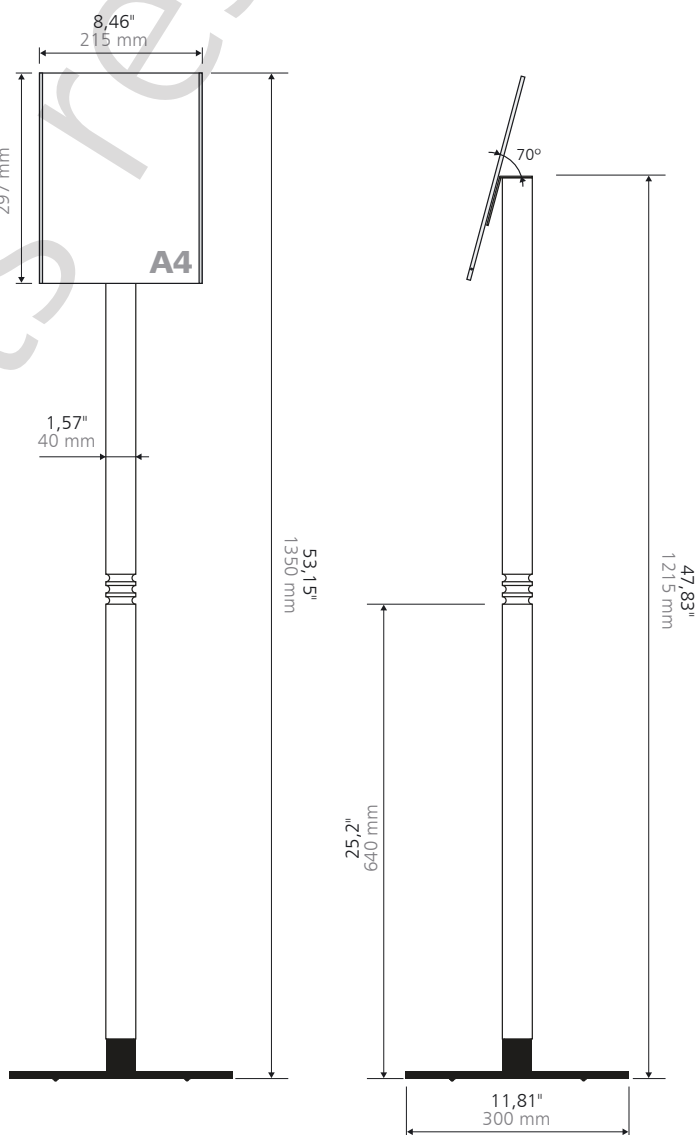

**finish**

**standards**

turned solid wood post with transparent matte varnish.

0,39" / 10mm welded steel base  
RAL 9005 black powder coating.